



NSC-200-25 SELF-CONTAINED COMPACTOR

Big-time muscle that keeps quiet.



Rock-solid waste equipment that outworks the competition

It's built to last because your business comes first.

- ✓ Quietest compactor on the market
- ✓ 5:1 compaction ratio—among the best available
- ✓ Highest quality UL and ETL listed components
- ✓ Most advanced electrical and hydraulic system
- ✓ Lowest-cost maintenance design
- ✓ Exceptional longevity
- ✓ 5-year industry-best warranty
- ✓ Market-leading service—before and after the sale

“

*In every measurable aspect,
we find that Nedland products exceed
the specifications of others who
make compactors. Their product
is second to none.*

—Steve Papai, President,
Automatic Response Systems

Applications

Ideally suited for food service, retail, healthcare, and education applications.

Dig into the details

Compactor features

- Replaceable UHMW polyethylene wear bars
- Bypass cylinders
- Secondary bottom rear door lock
- Fully-sealed, side-hinged clean-out door
- Fluid sump with drain
- Removable rear and top access panels
- Weatherproof control panel and power pack

Electrical/hydraulic features

- Controller power unit (PLC)
- Automatic shutdown with auto safety retract
- E-stop button
- Auto/manual selector
- Key lock on/off switch
- Automatic single cycle
- Multi-cycle timer
- Reverse button
- Remote control
- 80% and 100% full lights
- Fluid level and temp gauge
- Fluid-filled pressure gauge
- Inlet fluid strainer
- Left or right side hydraulic and electrical connections
- Low oil sensor shutdown
- Submersible power unit
- Synthetic biodegradable hydraulic fluid

Specs

Compactor capacity	2 cu yd
Container capacity	25 cu yd
Length	20'
Width	8'5"
Height	8'6"
Loading height	4'
Approx. weight	10,500 lbs
Compactor floor	3/8" AR steel plate with 3" structural channels
Compactor sides	1/4" steel plate sides with 4" x 2" x 1/4" & 6" x 2" x 1/4" structural steel tubing with 6" channel
Container floor	3/16" steel plate with 6" x 2" x 1/4" structural steel tubing rails with 1/2" x 2" steel bottom wear bars
Container sides & top	3/16" steel plate
Container width	Tapered front to rear
Full door seal	3/4" thick
Ram face & bottom	3/8" AR steel plate
Platen area	5' x 3'8" x 3'
Charge opening	3'6" x 5"
Ram penetration	12"
Breaker bar	6" x 6" x 1" with retaining teeth
Twin bypass cylinders	4" x 3'6" x 2-1/2"
Hydraulic cylinder mounts	6" x 6" x 1/2"
Hydraulic hose	15'
Hydraulic fluid	Biodegradable
Wear bars	Replaceable 1/2" UHMW polyethylene
Fluid sump	6"
Drain	4"
Line pressure	2,000 psi
Max line pressure	2,500 psi
Max ram force	63,000 lbs
Cycle time	45 sec
Fluid capacity	35 gal
Pump	10-1/2 gpm
Motor	10 hp 3-phase or single-phase inverter

Options

- Cart dumper system
- Container guide rails
- Enclosed doghouse with door and interlock
- Fluid reservoir heater
- Fullness monitoring system
- Open hopper for loading dock or ground loading
- Photo eye
- Side-loading hoppers
- Through-the-wall chutes
- Walk on or drive on deck with 42" safety rails

Schematics

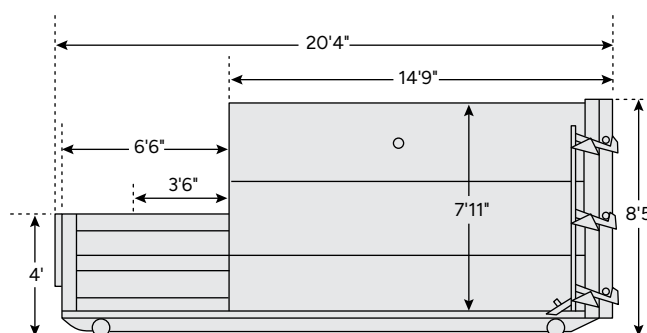

We refuse to cut corners

For 80+ years, our family-owned business has delivered exceptional quality, unparalleled service, and continuous innovation to the waste and recycling industry. Companies just like yours have counted on us—for decades.



Discover the Nedland difference

Give us a ring. There's nothing we love like talking trash (in a nice midwestern way).

+1-800-447-4925

nedland.com



Nedland Industries, Inc.

315 Railroad Street,
Ridgeland, WI 54763

This equipment conforms to all current ANSI Z 245.2 safety standards.

All sizes are approximate. Quality materials and product improvement are a continuous commitment at Nedland Industries. These specifications are subject to change without notice.