



NC-100 STATIONARY COMPACTOR WITH RECEIVER

Small footprint. Exceptional compaction force. Quiet operation.



Rock-solid waste equipment that outworks the competition

It's built to last because your business comes first.

- ✓ Quietest compactor on the market
- ✓ 5:1 compaction ratio—among the best available
- ✓ Highest quality UL and ETL listed components
- ✓ Most advanced electrical and hydraulic system
- ✓ Lowest-cost maintenance design
- ✓ Exceptional longevity
- ✓ 5-year industry-best warranty
- ✓ Market-leading service—before and after the sale

“

In every measurable aspect, we find that Nedland products exceed the specifications of others who make compactors. Their product is second to none.

—Steve Papai, President,
Automatic Response Systems

Applications

Ideally suited for retail, hotel, and healthcare applications.

Dig into the details

Compactor features

- Replaceable UHMW polyethylene wear bars
- Bypass cylinders
- Removable rear access panel
- Weatherproof control panel and power pack
- Container guide rails

Electrical/hydraulic features

- Controller power unit (PLC)
- Automatic shutdown with auto safety retract
- E-stop button
- Auto/manual selector
- Key lock on/off switch
- Automatic single cycle
- Multi-cycle timer
- Reverse button
- Remote control
- 80% and 100% full lights
- Fluid level and temp gauge
- Fluid-filled pressure gauge
- Inlet fluid strainer
- Left or right side hydraulic and electrical connections
- Low oil sensor shutdown
- Submersible power unit
- Synthetic biodegradable hydraulic fluid

Receiver containers

Rear-load	Front-load
4-yard	4-yard
6-yard	6-yard
8-yard	8-yard

Specs

Compactor capacity	1 cu yd
Length	5'4"
Width	4'10"
Height	4'1"
Loading height	3'7"
Approx. weight	3,400 lbs
Compactor floor	3/8" steel AR plate with 3" structural channels
Compactor sides	1/4" steel plate with 3" x 2" x 1/4" structural steel tubing
Ram face & bottom	3/8" AR steel plate
Platen area	3' x 2'7-1/2" x 4'
Charge opening	2'7" x 4'
Ram penetration	8"
Breaker bar	6" x 6" x 1/2" with retaining teeth
Twin bypass cylinders	2-1/2" x 3" x 1-1/2"
Hydraulic cylinder mounts	1/2" steel plate
Hydraulic hose	15'
Hydraulic fluid	Biodegradable
Wear bars	Replaceable 1/2" UHMW polyethylene
Line pressure	2,000 psi
Max line pressure	2,500 psi
Max ram force	19,500 lbs
Cycle time	40 sec
Fluid capacity	35 gal
Pump	5 gpm
Motor	5 hp/tri-volt, 3-phase or single-phase inverter

Options

- Cart dumper system
- Container guide rails
- Driver pack out
- Enclosed doghouse with door and interlock
- Fluid reservoir heater
- Fullness monitoring system
- Open hopper for loading dock or ground loading
- Photo eye
- Side-loading hoppers
- Through-the-wall chutes

Schematics

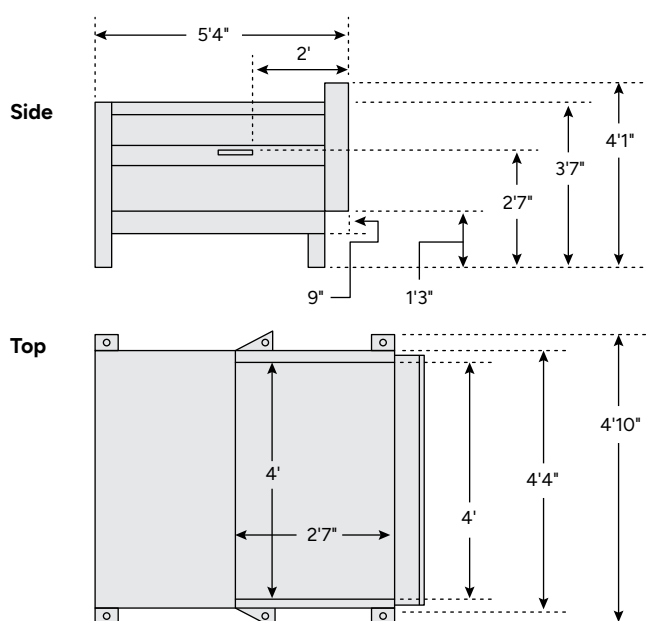

We refuse to cut corners

For 80+ years, our family-owned business has delivered exceptional quality, unparalleled service, and continuous innovation to the waste and recycling industry. Companies just like yours have counted on us—for decades.



Discover the Nedland difference

Give us a ring. There's nothing we love like talking trash (in a nice midwestern way).

+1-800-447-4925

nedland.com



Nedland Industries, Inc.

315 Railroad Street,
Ridgeland, WI 54763

This equipment conforms to all current ANSI Z 245.2 safety standards.

All sizes are approximate. Quality materials and product improvement are a continuous commitment at Nedland Industries. These specifications are subject to change without notice.