

Model NSC-100-15

NSC-100-15 Side View

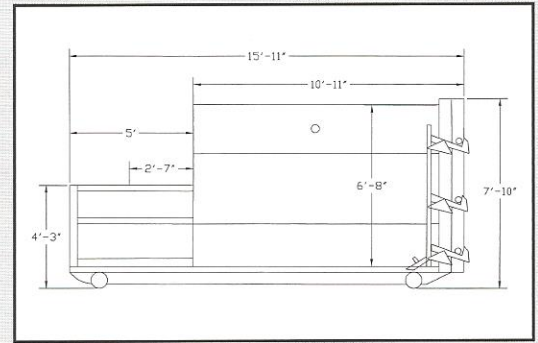

SPECIFICATIONS

Overall Length	15' 11"
Overall Width	101"
Overall Height	94"
Container Capacity	15 Cu. Yds
Compactor Capacity	1 Cu. Yds
Platen Area	36" x 31 1/2" x 48"
Charge Opening	31" x 48"
Ram Penetration	10"
Twin Cylinders	2 1/2" x 36" x 1"
Line Pressure	1500 PSI
Max Line Pressure	1950 PSI
Max Ram Force	19000 LBS
Cycle Time	40 Seconds
Fluid Capacity	2 Gallons
Pump	4.8L-.8H G.P.M.
Motor	2 HP 120-220 1 phase
App Weight	5900 LBS

COMPACTOR FEATURES

- 1/4" steel plate floor
- 3/16" steel plate sides with 3" x 2 1/4" structural steel tubing
- Breaker bar 6" x 6" x 1/2" with retaining teeth
- 1/2" steel plate hydraulic cylinder mounts
- Replaceable 1/2" UHMW polyethylene wear bars on all sides, tops and bottoms of platen for a smooth quiet and frictionless operation
- Weatherproof control panel and power pak
- Removable rear access panel

ELECTRICAL/HYDRAULIC FEATURES

- Automatic Single Cycle
- Reverse Button
- Full Light
- Automatic Shutdown
- Keyed Over-ride Switch
- Inlet Fluid Strainer
- Runs on 30 Amp 120V Service
- Moveable Left or Right Side Hydraulic and Electrical Connections

OPTIONS

- 3 HP-208/230/460-3 Phase
- Fluid Reservoir
- Multi-Cycle Timer
- Remote Control
- Open Hoppers (for loading dock or ground loading)
- Enclosed Doghouse With Door and Interlock
- Walk on or Drive on Deck With 42" Safety Rails
- Side Loading Hoppers
- Through-The-Wall Chutes
- Cart Dumper
- Container guide rails

CONTAINER FEATURES

- 1/8" steel plate floor with 4" x 2" x 1/4" structural steel tubing
- 1/8" steel plate sides and top
- Full 3/4" door seal
- Ratchet latch door closer
- Heavy duty hinges with grease fitting
- Tapered width from 58" at compactor to 68" at door

This Equipment Conforms to all Current ANSI Z 245.1 Safety Standards

NOTE: All sizes are approximate. Materials and product improvement is a continuous commitment at NEDLAND INDUSTRIES. These specifications are subject to change without notice.

1-(800) 447-4925 Toll Free - (715) 949-1983 Fax - 315 Railroad Street - Ridgeland, WI 54763